

# LEARNING TO FLY AT SEA LAND AIR

*Sea Land Air Flight Centre (SLA) is a new generation aviation service provider that offers you a unique experience of flight training and aircraft rental. Our mission is to provide the best level of flight training in Canada. Here is why many aspiring pilots, both local and abroad, select SLA as their flight school of choice:*



- We invest heavily on our fleet, offering the most modern, state-of-the-art aircraft that is unmatched by any flight school in BC. We train in **Diamond Aircraft**, including DA20s, DA40 and DA42, all of which is equipped with advanced avionics and navigation systems.
- **Ground School** courses are taught by experienced instructors in our multi-media classroom. Courses offered include:
  - ☑ Private Pilot Licence
  - ☑ Commercial Pilot Licence
  - ☑ G1000
  - ☑ Aviation English Course for ESL Students
- Flight Simulator: SLA is home to the **D-SIM-42 flight simulation training device** – the only of its kind in BC, and can also be used for IFR recurrency training and certification.
- **Online Booking System and Resources:** Book your lesson or reserve a flight 7/24 on our user-friendly website. There is also a host of aviation resources, including Flight Operation Manuals and Type Exams of our aircraft, available for download from our website.
- We are conveniently located at Boundary Bay Airport (CZBB), BC, Canada, just minutes away from Vancouver International Airport. Its location and close proximity to the US, aided by agreeable weather conditions, makes CZBB a prime flight training location.

*At SLA, we share your dream and passion for flying. Our enthusiastic, knowledgeable and professional staff works towards one goal: to provide the utmost service and exceed your expectations in every aspect of flight operations. We invite you to check out our facilities and services today.*

**Fly The New Generation. Fly Sea Land Air.**

UNIT 2A - 4340 KING STREET, DELTA, BC, CANADA V4K 0A5

Call us today at **604-940-6811** or visit **www.SeaLandAir.ca** for more details.



*British Columbia is one of the best places for flight training with its spectacular scenery and diverse weather conditions (long days and sunny in the summer, and rainy with the occasional snow in the winter). The high standard of the Canadian ICAO License is also recognized worldwide. Many Canada-trained pilots become successful professional pilots that fly for major commercial airlines.*

*Canada, as one of the most ethnically diverse countries in the world, provides a welcoming environment for international students. At SLA, our flight instructors have extensive international training experience and have great connections with flight schools abroad. Compared to other countries, training costs and rental rates are relatively low in Canada, thus giving your investment excellent value in terms of cost effectiveness.*

*SLA currently offers Private Pilot Licence and Commercial Pilot Licence courses to international students. Our website lists detailed information, requirements and application procedures for international students interested in completing their flight training in Canada. We encourage you to visit our website for the most updated information. Below is a summary to get you started.*

## HOW TO GET STARTED

---

### ■ **Visa Requirements**

First of all, you need to determine visa requirements when you are considering studying in Canada as a foreign student. In general, you do not need a visa to study in Canada if the duration of your stay/training is less than 6 months. Otherwise, a Study Permit is required. In addition, citizens from some countries require a visa to enter Canada regardless of the duration of stay. In such case, you will need to submit to the Canadian Consulate the following to apply for a Study Permit:

- ☑ *Original copy of Letter of Acceptance from SLA authorizing you to train at our Flight Centre.*
- ☑ *Proof that you have sufficient funds to pay for tuition, living expenses, return transportation and other necessary costs for the duration of your stay in Canada.*
- ☑ *Proof that you will be returning to your home country upon completion of the course/training.*
- ☑ *Medical/aviation medical certificate.*
- ☑ *Security information to ensure that you are not a security risk to Canada.*

### ■ **Courses and Rates**

Our website shows detailed course requirements and rates of available packages. PPL package starts from CAD8,110 and CPL package from CAD30,450, both based on Transport Canada minimum requirements. Most students however require more than the minimum required hours to complete the course, therefore, we recommend students to reserve approximately 25% in extra funding to complete the course.

### ■ **Accommodation**

Once visa requirements are sorted out and your application has been approved, SLA can provide assistance in making traveling and accommodation arrangement in Canada. Many students opt for homestay arrangement to fully exploit their experience in Canada; and the cost is approximately CAD700 per month.

*For more information about visa and Study Permit requirements, please refer to our website – International Students.*

---

*SLA is committed to providing a one-stop service to international students. Our goal is to ensure our students a rewarding and enjoyable learning experience in Canada. To enable us to further assist you in your application, please complete the International Student Application Form to get started on the process immediately.*

***For detailed information about learning to fly at SLA, please visit our website [www.SeaLandAir.ca](http://www.SeaLandAir.ca).***

---

## Our Diamond Aircraft Fleet

Diamond Aircraft's fleet of certified, composite aircraft represents the best engineered and most competent aircraft in the market. It also holds one of the best safety records on the General Aviation market and is the most efficient GA aircraft flying today. Just like Diamond Aircraft, Sea Land Air is committed to bringing leading edge technology to the market. With our fleet of Diamond Aircraft, including DA20-A1 (80 HP and 100HP), DA20-C1, DA40 and DA42 TDI, we are proud to be able to provide students and pilots with exceptional aviation experiences.

### **Aircraft Specifications:**

	DA20-A1	DA20-C1	DA40	DA42 TDI (Twin)
Engine	Rotax 912	TCM IO-240-B3B	Lycoming IO-360-M1A	Centurion 2.0 turbo Diesel
Horsepower	80 /100 hp	125 hp	180 hp	270 hp
Wing Span	35 ft 6.7 in	35 ft 8 in	39 ft 2 in	44 ft
Max. T/O Weight	1,609 lbs	1,764 lbs	2,535 lbs	3,935 lbs
Fuel capacity, usable	19.5 gal	24.0 gal	48.0 gal	50.0 gal (76.4 gal with aux. tanks)
Stall speed, full flaps	37 kts	45 kts	49 kts	57 kts (Gear down)
Max. demonstrated crosswind	15 kts	20 kts	20kts	20kts

Three-View Drawing of DA20-C1 Aircraft

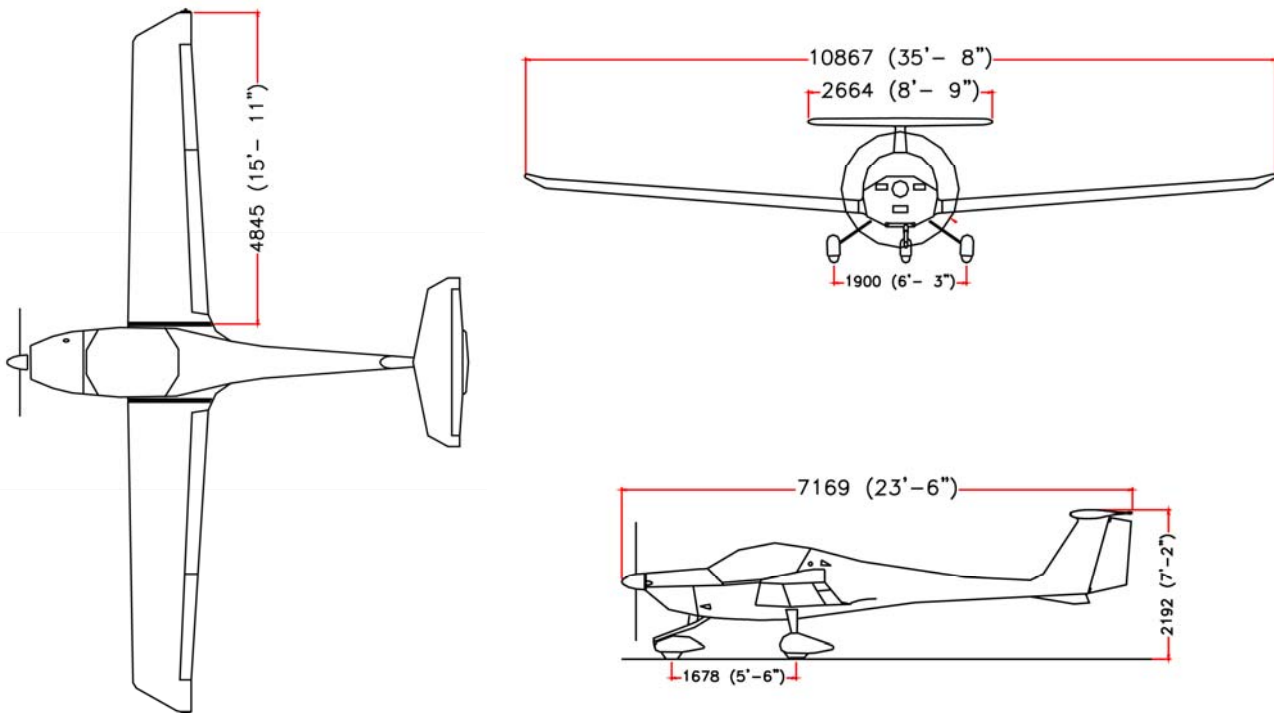

Three-View Drawing of Diamond DA40

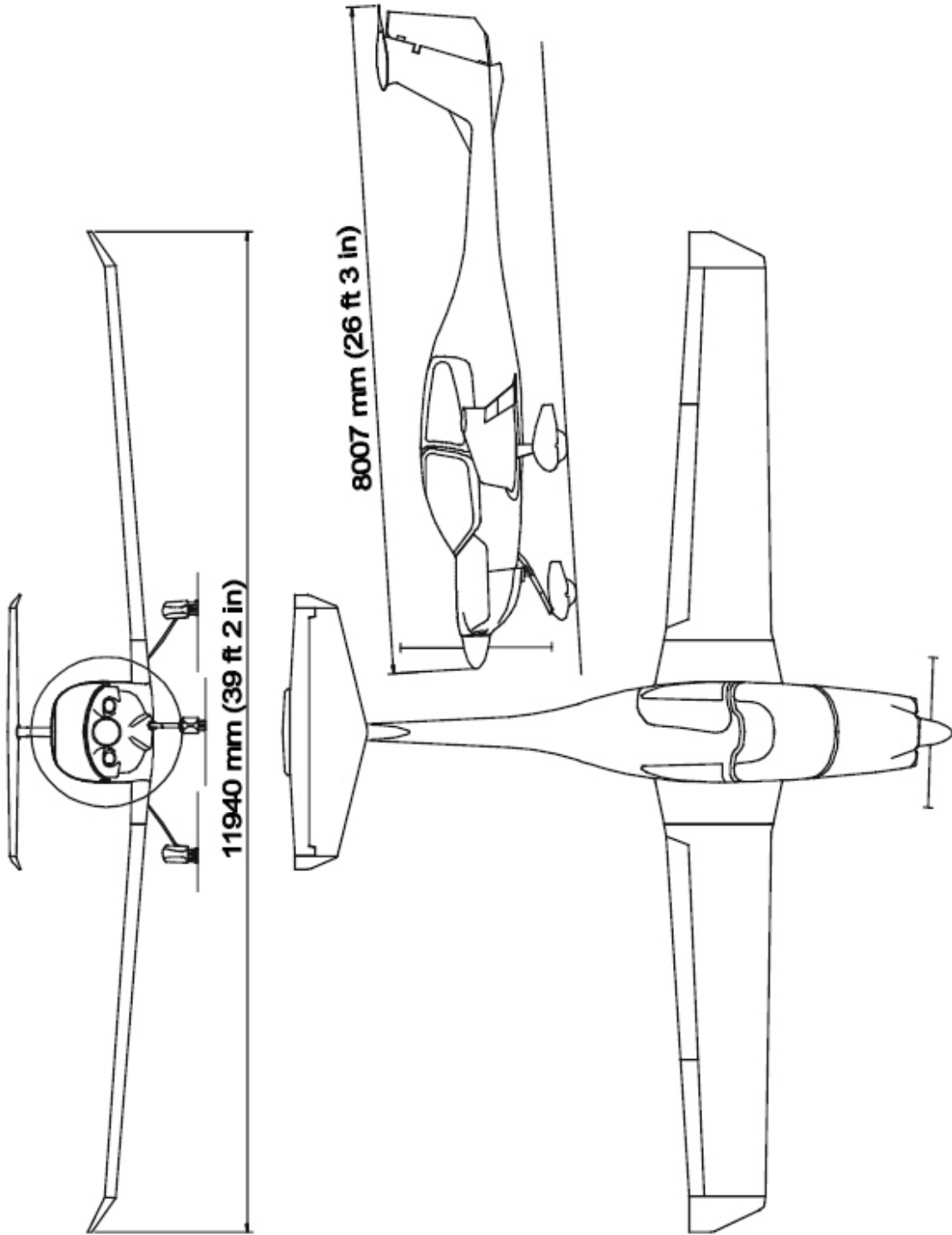



Three-View Drawing of Diamond DA42 TDI

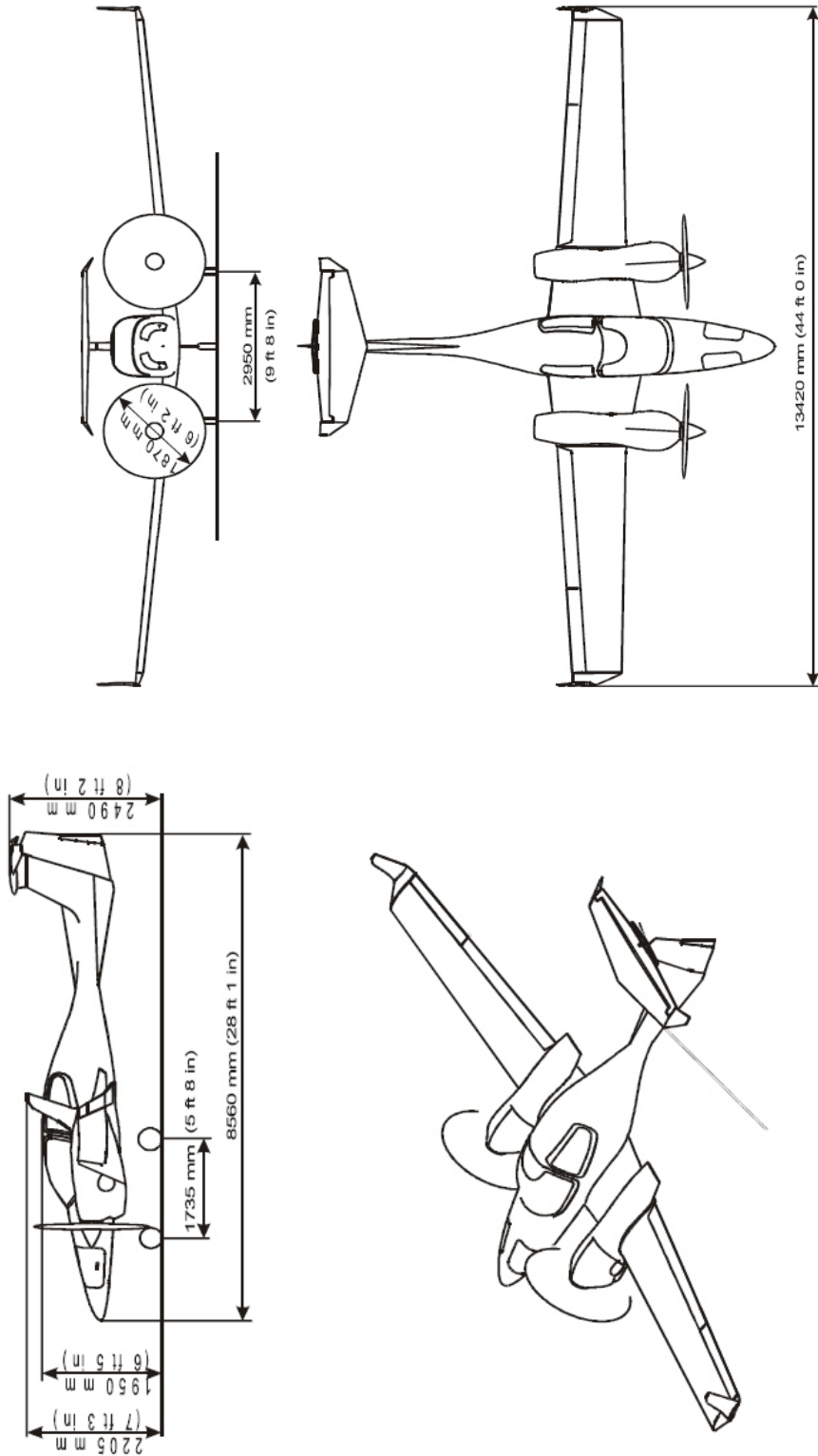

## Private Pilot Licence

The journey of flying typically begins with the Private Pilot Licence. By receiving your Private Pilot licence, you will have proven to have mastered the fundamentals of airmanship, navigation, and communication. The Private Pilot can fly virtually anywhere under Visual Flight Rules (VFR) while taking passengers along for the adventure.

Transport Canada Required Minimums for Private Pilot Licence			
Minimum Age: 17			
Required: Category 1 or Category 3 Medical Certificate			
Flight Training Requirement			
	Available Packages		
	DA20-A1 @ \$118/hr solo \$168/hr dual	DA20-C1 @ \$145/hr solo \$195/hr dual	DA40 @ \$195/hr solo \$245/hr dual
17 hours Dual Flight Time including at least 3 hours cross-country flying and 5 hours of instrument flight time	\$2,856.00	\$3,315.00	\$4,165.00
12 hours Solo Flight Time	\$1,416.00	\$1,740.00	\$2,340.00
16 hours Completion Flight Time based on total flight time of at least 45 hours	\$1,888.00	\$2,320.00	\$3,120.00
20 hours of pre-flight and post-flight ground briefings (\$50/hour)	\$1,000.00	\$1,000.00	\$1,000.00
40 hours Ground School Course	\$350.00	\$350.00	\$350.00
Ground School Kit	\$150.00	\$150.00	\$150.00
Complete a Flight Test	\$450.00	\$450.00	\$450.00
<b>Total Estimated Cost*:</b>	<b>\$8,110.00</b>	<b>\$9,325.00</b>	<b>\$11,575.00</b>

*Note: Prices are based on Transport Canada minimum requirements. Students may require an additional of 15 hours in flight training (12 hours dual and 3 hours solo) and ground briefing time before each flight with instructor. Therefore, students should allow for approximately **25% additional** funding for the completion of the Canadian Private Pilot Licence. Block time rental is available which will reduce the overall cost. Please check our website for details. All prices are in CAD and are subject to change without prior notice.*



## Commercial Pilot Licence

A Commercial Pilot's Licence represents the level of piloting expertise for a pilot who intends to "fly for hire." The expectations for knowledge and skill include a Commercial Pilot level of knowledge, advanced maneuvers with an emphasis on coordination and precision, and the skills to operate a complex airplane.

A Pilot who intends to fly professionally will seek the CPL as a requirement to practice the profession. A business or recreational flyer will seek the CPL for a higher level of safety and proficiency as well as lower insurance rates, especially in complex airplanes.

<b>Transport Canada Required Minimums for Commercial Pilot Licence</b>			
Minimum Age: 18			
Required: Category 1 Medical Certificate			
Flight Training Requirement			
	Available Packages		
	DA20-A1 @ \$118/hr solo \$168/hr dual	DA20-C1 @ \$145/hr solo \$195/hr dual	DA40 @ \$195/hr solo \$245/hr dual
Private Pilot Licence Training Fees	\$8,110.00	\$9,325.00	\$11,575.00
35 hours Dual Flight Training	\$5,880.00	\$6,825.00	\$8,575.00
120 hours Solo Flight Time <i>Total time required: 200 hours of flight time, and 100 hours of pilot-in-command</i>	\$14,160.00	\$17,400.00	\$23,400.00
20 hours of pre-flight and post-flight ground briefings (\$50/hour)	\$1,000.00	\$1,000.00	\$1,000.00
80 hours Commercial Ground School Course	\$700.00	\$700.00	\$700.00
Ground School Kit <i>(Not required if completed PPL Ground School Course with Sea Land Air)</i>	\$150.00	\$150.00	\$150.00
Complete a Flight Test	\$450.00	\$450.00	\$450.00
<b>Total Estimated Cost*:</b>	<b>\$30,450.00</b>	<b>\$35,850.00</b>	<b>\$45,850.00</b>

*Note: Prices are based on Transport Canada minimum requirements. Most students require more than the minimum number of hours to prepare for their flight test; therefore, estimated cost will vary accordingly. Block time rental is available which will reduce the overall cost. Please check our website for details. All prices are in CAD and are subject to change without prior notice.*

## Night Rating

Discover a whole new dimension and enjoy one of the most beautiful and peaceful times to fly – at night! The Night Rating endorsement builds on the Private Pilot Licence, and allows the holder to fly any single-engine or multi-engine non-high performance aircraft during the hours of darkness in visual meteorological conditions under Visual Flight Rules (VFR). The applicant must hold a valid Private Pilot Licence or higher to be eligible for Night Rating training. Minimum training requirements are set out below. No flight test or written examination is required.

<b>Transport Canada Required Minimums for Night Rating</b>			
Flight Training Requirement			
	Available Packages		
	<b>DA20-A1</b> @ \$118/hr solo \$168/hr dual	<b>DA20-C1</b> @ \$145/hr solo \$195/hr dual	<b>DA40</b> @ \$195/hr solo \$245/hr dual
10 hours Dual Flight Time <i>At least 2 hours dedicated to cross-country requirement.</i> <i>At least 5 hours instrument flight time in addition to the 5 hours training received during private pilot licence training.</i>	\$1,680.00	\$1,950.00	\$2,450.00
5 hours Solo Flight Time <i>At least 10 takeoffs, circuits and landings</i>	\$590.00	\$725.00	\$975.00
<b>Total Estimated Cost*:</b>	<b>\$2,270.00</b>	<b>\$2,675.00</b>	<b>\$3,425.00</b>

*Note: Prices are based on Transport Canada minimum requirements. Most students require more than the minimum number of hours to prepare for their flight test; therefore, estimated cost will vary accordingly. Block time rental is available which will reduce the overall cost. Please check our website for details. All prices are in CAD and are subject to change without prior notice.*

## Multi-Engine Rating

The Multi-Engine Class Rating allows you to fly multi-engine aircraft with more complex systems. Considered mandatory by most Commercial Operations, the Multi-Engine Class Rating will also benefit the Private Pilot by allowing more operational capability and flexibility as to when and where to fly due to the additional safety of having two engines.

Building on the skills from your previous training you will learn to operate the aircraft and its systems as per the aircraft manual. Course emphasis will be placed on advanced systems, multi-engine performance and emergency drills to ensure the required knowledge and skill is acquired for the student to confidently pilot an advanced multi engine aircraft.

Building on your single-engine flight experience, the Multi-Engine Class Rating definitely will take your flying to the next level.

<b>Multi-Engine Rating Package</b>	
<b>Prerequisite:</b> Private Pilot Licence (or higher)	
<b>Requirement:</b> (Note that there is no minimum time requirement and no written test required by Transport Canada)	
<b>Description</b>	
	<b>Multi Engine Rating Package</b> <b>Diamond Twin Star DA42 TDI</b> @ \$330/hr solo \$380/hr dual
6 hours Dual Training in the D-Sim-42 (G1000) Flight Training Device @ \$150/hr	\$900.00
5 hours Dual Instrument Flight Time on DA42	\$1,900.00
11.3 hours Ground Briefing	\$565.00
Multi-Engine Manual	\$80.00
Flight Test (1.2hr aircraft rental + flight test fee)	\$696.00
<b>Total Package Cost:</b>	<b>\$4,141.00</b>

*Note: Students may require more than the number of hours to prepare for their flight test; therefore, estimated cost will vary accordingly. All prices are in CAD and are subject to change without prior notice.*

## Group 1 Instrument Rating (Multi Engine) with G1000

The Instrument Rating allows you to fly in cloud navigating solely by reference to the flight and navigation instruments. Building on the skills from your previous training you will learn to control the aircraft precisely "on the instruments" to fit in the air traffic system. As a result you will be able to fly safely when visual navigation is marginal or not possible.

Considered mandatory by most Commercial Operations, the Instrument Rating will also benefit the Private Pilot by allowing more capability and flexibility as to when to fly, and the background knowledge of man, environment and machine, to know when not to fly.

Building on your visual flight experience, the Instrument Rating definitely will take your flying to the next level.

<b>Transport Canada Required Minimums for Multi-Engine Instrument Rating</b>	
<p><b>Prerequisite:</b> Private Pilot Licence (or higher), 50 hours of cross country PIC and 5 hrs of logged instrument time.</p> <p><b>Requirement:</b> 40 hours of instrument time, a dual cross-country of at least 100 nautical miles, under simulated or actual IFR conditions must be completed and a Transport Canada Written and Flight Test must be completed.</p>	
<b>Description</b>	
	<b>Multi Engine Instrument Rating Package</b> <b>Diamond Twin Star DA42 TDI</b> @ \$330/hr solo \$380/hr dual
20 hours Dual Training in the D-Sim-42 (G1000) Flight Training Device @ \$150/hr	\$3,000.00
15 hours Dual Instrument Flight Time	\$5,700.00
17.4 hours Ground Briefing	\$870.00
IFR course manual	\$80.00
Flight Test (1.4hr aircraft rental + flight test fee)	\$762.00
<b>Total Package Cost:</b>	<b>\$10,412.00</b>

*Note: Prices are based on Transport Canada minimum requirements. Students may require more than the minimum number of hours to prepare for their flight test; therefore, estimated cost will vary accordingly. All prices are in CAD and are subject to change without prior notice.*